

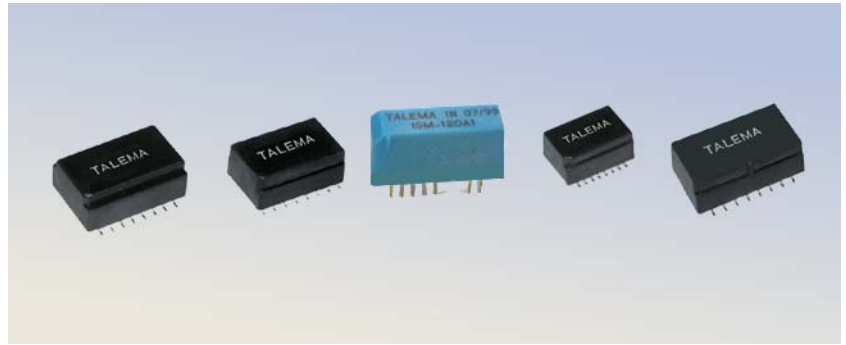

## IC - S<sub>0</sub> Interface Module Selection Guide

Talema manufactures a wide range of signal transformers for all S<sub>0</sub> ISDN applications. Space saving modules, available in through hole and surface mount packages, offer a cost effective alternative to individual transformers and chokes and are compatible with all common IC's. A complete listing of transceiver IC's with recommended Talema transformer modules is listed on the following cross reference chart.



Performance has been proven in the many design-in's of our products in these applications. Quality and consistency is guaranteed through 100% testing of the specified parameters for Primary Inductance, Leakage Inductance, Turns Ratio, DC resistance and Interwinding Capacitance. This ensures that the Return Loss and Pulse Waveshape requirements for S-Interface can be met. Additionally, all parts are tested for 1500V minimum isolation.

**Standard Packaging:** SMD styles - Tape and Reel; TH styles - Anti Static tubes.

### ISDN IC - S<sub>0</sub> Interface Module Cross Reference Guide

IC Manufacturer	IC Part Number	Talema Part Number				
		Vertical Mount DIL		Surface Mount		
		IEC 950 Approved	Standard	IEC 950 Reinforced Insulation	Standard/ Compact	Miniature
Alcatel Micro	MTC20276, MTC20277, MTC202172	HVM-120A1 HVM-140C1	ISM-120A1 ISM-140C1	MHJ-240B1	MSJ-403A MAJ-403A	MUJ-103A
Cologne Chip	HFC-Sxxx Series	HVM140C1	ISM-140C1	MHJ-240B1	MSJ-403A MAJ-403A	MUJ-103A
Legerity (AMD)	AM79C30A, AM79C32A	HVM-201A1 HVM-140C1	ISM-120A1 ISM-140C1	MHJ-240B1	MSJ-403A MAJ-403A	MUJ-103A
Lucent	T7234, T7250, T7254, T7256, T7259	HVM-130C1	ISM-130C1	MHJ-230B1	MSJ-405A MAJ-405A	MUJ-105A
	T7901, T7903	HVM-201A1 HVM-140C1	ISM-120A1 ISM-140C1	MHJ-240B1	MSJ-403A MAJ-403A	MUJ-103A
Mietec	MTC-2072	HVM-120A1 HVM-140C1	ISM-120A1 ISM-140C1	MHJ-240B1	MSJ-403A MAJ-403A	MUJ-103A
Mitel	MT8930, MT8931	HVM-201A1 HVM-140C1	ISM-120A1 ISM-140C1	MHJ-240B1	MSJ-403A MAJ-403A	MUJ-103A
Motorola	MC145474, MC145475	HVM-100C1	ISM-100C1	MHJ-200B1	MSJ-400A MAJ-400A	MUJ-100A
	MC145574	HVM-130C1	ISM-130C1	MHJ-230B1	MSJ-405A MAJ-405A	MUJ-105A
National	TP3420, TP3421	HVM-201A1 HVM-140C1	ISM-120A1 ISM-140C1	MHJ-240B1	MSJ-403A MAJ-403A	MUJ-103A
NEC	D98201	HVM-201A1 HVM-140C1	ISM-120A1 ISM-140C1	MHJ-240B1	MSJ-403A MAJ-403A	MUJ-103A
SGS	ST5420, ST5421	HVM-201A1 HVM-140C1	ISM-120A1 ISM-140C1	MHJ-240B1	MSJ-403A MAJ-403A	MUJ-103A
Infineon	PEB2080, 2082, 2084, 2085, 2086 PSB2115, PSB2116	HVM-201A1 HVM-140C1	ISM-120A1 ISM-140C1	MHJ-240B1	MSJ-403A MAJ-403A	MUJ-103A
	PEB8090, 8091, 8190, 8191 PEB21381(5V), PEB21383(5V)	HVM-201A1 HVM-140C1	ISM-120A1 ISM-140C1	MHJ-240B1	MSJ-403A MAJ-403A	MUJ-103A
	PSB21381(3.3V), PSB21382, PSB21384 PSB21283(3.3V), PEB3086, PSB31864	HVM-100C1	ISM-100C1	MHJ-200B1	MSJ-400A MAJ-400A	MUJ-100A
VLSI	VNS8000	HVM-201A1 HVM-140C1	ISM-120A1 ISM-140C1	MHJ-240B1	MSJ-403A MAJ-403A	MUJ-103A
Yamaha	YN7405	HVM-201A1 HVM-140C1	ISM-120A1 ISM-140C1	MHJ-240B1	MSJ-403A MAJ-403A	MUJ-103A



# ISDN S<sub>0</sub> Miniature SMD Interface Modules

## Features

- excellent output characteristics ensure compliance with CCITT.I.430 pulse waveform template when used with recommended IC pairing
- SMD modules are designed for pick and place compatibility
- excellent and consistent balance between windings
- modular design maximizes suppression effectivity and transmission properties
- full compatibility with all common IC's
- manufactured in ISO-9001:2000, TS-16949:2002 and ISO-14001:2001 certified Talema facility
- fully RoHS compliant and meets lead free reflow level J-STD-020C
- operating temperature: -40° to 85°C
- storage temperature: -40 to +125°C

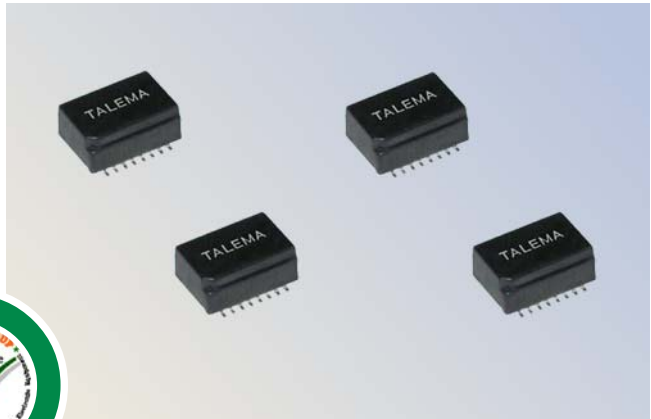

## Electrical Specifications @ 25°C

Turns Ratio: **Bold** = IC side windings

### Miniature Chip SMD Modules comply with Basic Insulation Level EN60950, UL1950 and UL1459

Part Number	L <sub>P</sub> (mH Min)	Turns Ratio	L <sub>L</sub> (μH Max)	C <sub>C</sub> (pF Max)	R <sub>CU</sub> P (Ohms)	R <sub>CU</sub> S (Ohms)	V <sub>P</sub> (Vrms)	Schematic
MUJ-100A or B-XXX	25	1:1:1:1	5	50	2.7	3.3	1500	A or B
MUJ-103A or B-XXX	25	1:1: <b>2:2</b>	5	50	3.7	8.4	1500	A or B
MUJ-105A or B-XXX	25	1:1: <b>2.5:2.5</b>	5	50	5.2	10.5	1500	A or B

### Common Mode Choke

Basic P/N + Suffix	L <sub>N</sub> (μH)	R <sub>CU</sub> (Ohms)	Basic P/N + Suffix	R <sub>CU</sub> (Ohms)	Basic P/N + Suffix	R <sub>CU</sub> (Ohms)
MUJ-100A-000	No Choke		MUJ-103A -000	No Choke	MUJ-105A-000	No Choke
MUJ-100A or B-500	50	0.4	MUJ-103A or B-500	0.5	MUJ-105A or B-500	0.7
MUJ-100A or B-101	100	0.5	MUJ-103A or B-101	0.6	MUJ-105A or B-101	0.9
MUJ-100A or B-501	500	0.4	MUJ-103A or B-501	0.6	MUJ-105A or B-501	0.8
MUJ-100A or B-502	5000	0.8	MUJ-103A or B-502	0.9	MUJ-105A or B-502	1.5

## Test Conditions:

Polarity and Turns Ratio: ±1%

Inductance: 25mH minimum, line side windings in series @ 10kHz, 100mV

Leakage Inductance: Line side windings in series, IC side windings short circuited - measurement @ 100kHz, 100mV

Coupling capacitance: IC side windings in series to Line side windings in series @ 10kHz, 100mV

Common Mode Choke Inductance: 100kHz, 20mV

Test Voltage: 1.5kV for 2 Sec. - Line side windings in series to IC side windings in series

Standard Packaging: Tape and Reel

## MUJ Miniature Module

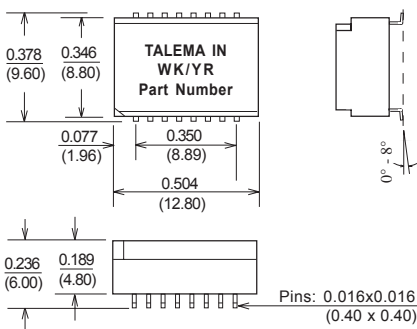

Surface Coplanarity will be 0.004 (0.10)

Dimensions: Inches (Millimeters)

Tolerance: ±0.010 (0.25) unless specified otherwise

## Suggested Pad Layout

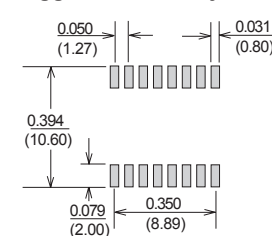

## Schematic (Without Choke)

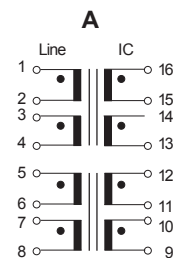

## Schematics - With Choke

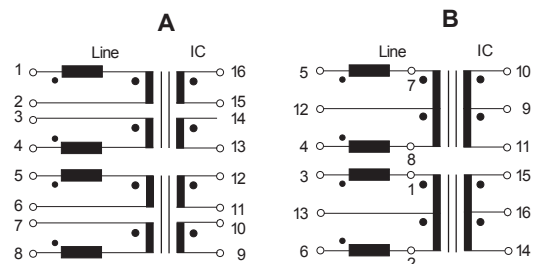

# ISDN S<sub>0</sub> Miniature SMD Interface Modules

## Features

- excellent output characteristics ensure compliance with CCITT.I.430 pulse waveform template when used with recommended IC pairing
- SMD modules are designed for pick and place compatibility
- excellent and consistent balance between windings
- modular design maximizes suppression effectivity and transmission properties
- full compatibility with all common IC's
- manufactured in ISO-9001:2000, TS-16949:2002 and ISO-14001:2001 certified Talema facility
- fully RoHS compliant and meets lead free reflow level J-STD-020C
- operating temperature: -40° to 85°C
- storage temperature: -40 to +125°C

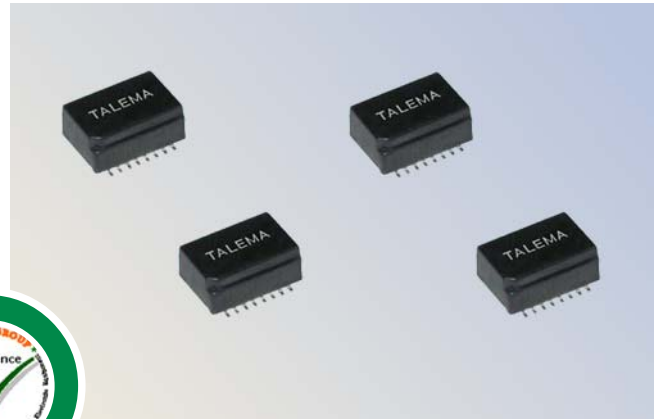

## Electrical Specifications @ 25°C

Turns Ratio: **Bold** = IC side windings

Miniature Chip SMD Modules comply with Basic Insulation Level EN60950, UL1950 and UL1459

Part Number	L <sub>P</sub> (mH Min)	Turns Ratio	L <sub>L</sub> (μH Max)	C <sub>C</sub> (pF Max)	R <sub>CU</sub> P (Ohms)	R <sub>CU</sub> S (Ohms)	V <sub>P</sub> (Vrms)	Schematic
MMJ-100A or B-XXX	25	1:1:1:1	5	50	2.7	3.3	1500	A or B
MMJ-103A or B-XXX	25	1:1: <b>2:2</b>	5	50	3.7	8.4	1500	A or B
MMJ-105A or B-XXX	25	1:1: <b>2.5:2.5</b>	5	50	5.2	10.5	1500	A or B

### Common Mode Choke

Basic P/N + Suffix	L <sub>N</sub> (μH)	R <sub>CU</sub> (Ohms)	Basic P/N + Suffix	R <sub>CU</sub> (Ohms)	Basic P/N + Suffix	R <sub>CU</sub> (Ohms)
MMJ-100A-000	No Choke		MMJ-103A -000	No Choke	MMJ-105A-000	No Choke
MMJ-100A or B-500	50	0.4	MMJ-103A or B-500	0.5	MMJ-105A or B-500	0.7
MMJ-100A or B-101	100	0.5	MMJ-103A or B-101	0.6	MMJ-105A or B-101	0.9
MMJ-100A or B-501	500	0.4	MMJ-103A or B-501	0.6	MMJ-105A or B-501	0.8
MMJ-100A or B-502	5000	0.8	MMJ-103A or B-502	0.9	MMJ-105A or B-502	1.5

## Test Conditions:

Polarity and Turns Ratio: ±1%

Inductance: 25mH minimum, line side windings in series @ 10kHz, 100mV

Leakage Inductance: Line side windings in series, IC side windings short circuited - measurement @ 100kHz, 100mV

Coupling capacitance: IC side windings in series to Line side windings in series @ 10kHz, 100mV

Common Mode Choke Inductance: 100kHz, 20mV

Test Voltage: 1.5kV for 2 Sec. - Line side windings in series to IC side windings in series

Standard Packaging: Tape and Reel

## MMJ Miniature Module

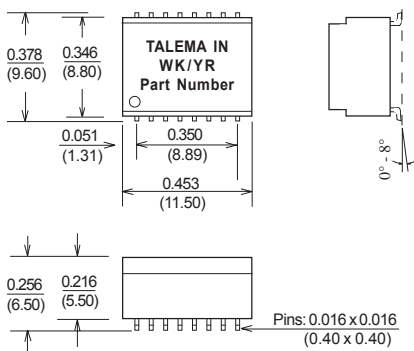

## Suggested Pad Layout

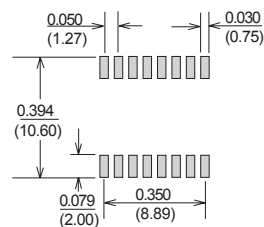

## Schematic (Without Choke)

### A

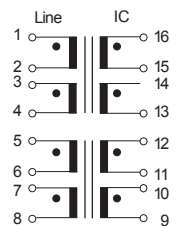

## Schematics - With Choke

### A

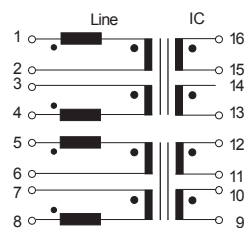

### B

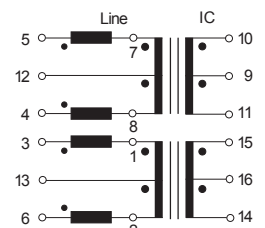

Surface Coplanarity will be 0.004 (0.10)

Dimensions: Inches (Millimeters)

Tolerance: ±0.010 (0.25) unless specified otherwise



## ISDN S<sub>0</sub> Compact SMD Interface Modules

### Features

- excellent output characteristics ensure compliance with CCITT.I.430 pulse waveform template when used with recommended IC pairing
- SMD modules are designed for pick and place compatability
- excellent and consistent balance between windings
- modular design maximizes suppression effectivity and transmission properties
- full compatibility with all common IC's
- manufactured in ISO-9001:2000, TS-16949:2002 and ISO-14001:2001 certified Talema facility
- fully RoHS compliant and meets lead free reflow level J-STD-020C
- operating temperature: -40° to 85°C
- storage temperature: -40 to +125°C

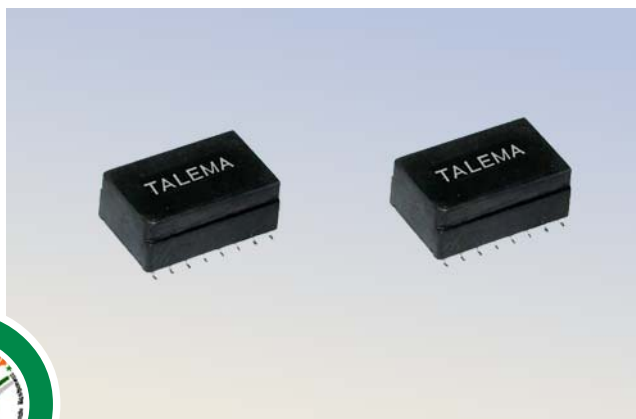

### Electrical Specifications @ 25°C

Turns Ratio: **Bold** = IC side windings

**Compact SMD Modules comply with Basic Insulation Level EN60950, UL1950 and UL1459**

Part Number	L <sub>P</sub> (mH Min)	Turns Ratio	L <sub>L</sub> (μH Max)	A <sub>I<sub>DC</sub></sub> (mA)	C <sub>C</sub> (pF Max)	R <sub>CU<sub>P</sub></sub> (Ohms)	R <sub>CU<sub>S</sub></sub> (Ohms)	V <sub>P</sub> (Vrms)	Schematic
MAJ-400A-XXX	30	1:1:1:1	5	4	120	1.7	1.7	1500	A
MAJ-403A-XXX	30	1:1: <b>2:2</b>	5	4	120	1.7	3.4	1500	A
MAJ-405A-XXX	30	1:1: <b>2.5:2.5</b>	5	4	120	1.9	4.4	1500	A
MAJ-400A-XXX-3	30	1:1:1:1	5	3	120	1.7	1.7	1500	A
MAJ-403A-XXX-3	30	1:1: <b>2:2</b>	5	3	120	1.7	3.4	1500	A
MAJ-405A-XXX-3	30	1:1: <b>2.5:2.5</b>	5	3	120	1.9	4.4	1500	A

#### Common Mode Choke

Basic P/N + Suffix (Example: MAJ-403A-470)	L <sub>N</sub> (μH)	R <sub>CU</sub> (Ohms)
-000	No Choke	
-470	47	0.5
-101	100	0.7
-501	500	0.5
-502	5000	2.0

### Test Conditions:

Polarity and Turns Ratio: ±1%

Inductance: 30mH minimum, line side windings in series @ 10kHz, 100mV

Leakage Inductance: Line side windings in series, IC side windings short circuited @ 100kHz, 100mV

Coupling Capacitance: IC side windings in series to Line side windings in series @ 10kHz, 100mV

Common Mode Choke Inductance: 100kHz, 20mV

Test Voltage: 1.5kV for 2 Sec. - Line side windings in series to IC side windings in series

Standard Packaging: Tape and Reel

### MAJ Compact Chip Module

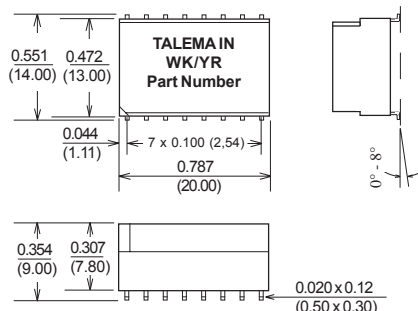

### Suggested Pad Layout

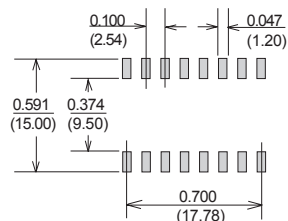

### Schematic

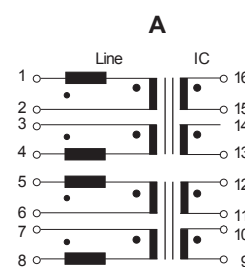

Surface Coplanarity will be 0.004(0.10) maximum

Dimensions: Inches (Millimeters)

Tolerance: ±0.010 (0.25) unless specified otherwise

# ISDN S<sub>0</sub> Miniature SMD Interface Modules

## Features

- excellent output characteristics ensure compliance with CCITT.I.430 pulse waveform template when used with recommended IC pairing
- SMD modules are designed for pick and place compatability
- excellent and consistent balance between windings
- modular design maximizes suppression effectivity and transmission properties
- full compatibility with all common IC's
- manufactured in ISO-9001:2000, TS-16949:2002 and ISO-14001:2001 certified TALEMA facility
- fully RoHS compliant and meets lead free reflow level J-STD-020C
- operating temperature: -40° to 85°C
- storage temperature: -40 to +125°C

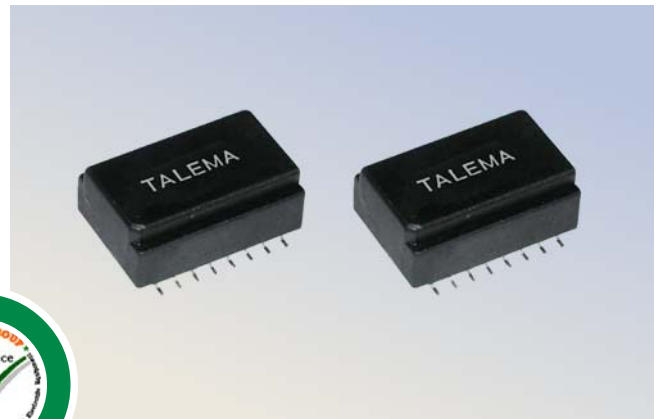

## Electrical Specifications @ 25°C

Turns Ratio: **Bold** = IC side windings

**Compact SMD Modules comply with Basic Insulation Level EN60950, UL1950 and UL1459**

Part Number	L <sub>P</sub> (mH Min)	Turns Ratio	L <sub>L</sub> (μH Max)	I <sub>DC</sub> (mA)	C <sub>C</sub> (pF Max)	R <sub>CU</sub> P (Ohms)	R <sub>CU</sub> S (Ohms)	V <sub>P</sub> (Vrms)	Schematic
MSJ-400A-XXX	30	1:1:1:1	10	4	150	1.7	2.0	1500	A
MSJ-403A-XXX	30	1:1: <b>2:2</b>	10	4	150	1.7	4.0	1500	A
MSJ-405A-XXX	30	1:1: <b>2.5:2.5</b>	10	4	150	1.7	4.6	1500	A

### Common Mode Choke

Basic P/N + Suffix (Example: MSJ-403A-470)	L <sub>N</sub> (μH)	R <sub>CU</sub> (Ohms)
-000	No Choke	
-470	47	0.5
-101	100	0.7
-501	500	0.5
-502	5000	2.0

## Test Conditions:

Polarity and Turns Ratio: ±1%

Inductance: 30mH minimum, line side windings in series @ 10kHz, 100mV

Leakage Inductance: Line side windings in series, IC side windings short circuited @ 100kHz, 100mV

Coupling Capacitance: IC side windings in series to Line side windings in series @ 10kHz, 100mV

Common Mode Choke Inductance: 100kHz, 20mV

Test Voltage: 1.5kV for 2 Sec. - Line side windings in series to IC side windings in series

Standard Packaging: Tape and Reel

## MSJ Module

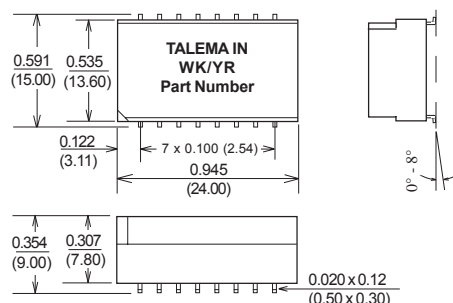

## Suggested Pad Layout

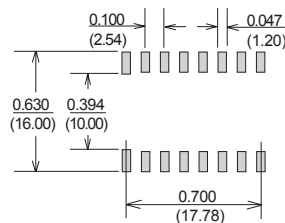

## Schematic

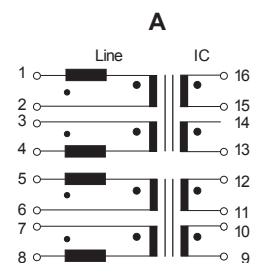

Surface Coplanarity will be 0.004(0.10) maximum

Dimensions: Inches (Millimeters)

Tolerance: ±0.010 (0.25) unless specified otherwise



## MHJ Series S<sub>0</sub> 3kV Interface Transformer Modules

### Features

- excellent output characteristics ensure compliance with CCITT.I.430 pulse waveform template when used with recommended IC pairing
- SMD modules are designed for pick and place compatibility
- excellent and consistent balance between windings
- modular design maximizes suppression effectivity and transmission properties
- full compatibility with all common IC's
- manufactured in ISO-9001:2000, TS-16949:2002 and ISO-14001:2001 certified Talema facility
- fully RoHS compliant and meets lead free reflow level J-STD-020C
- operating temperature: -40° to 85°C
- storage temperature: -40 to +125°C

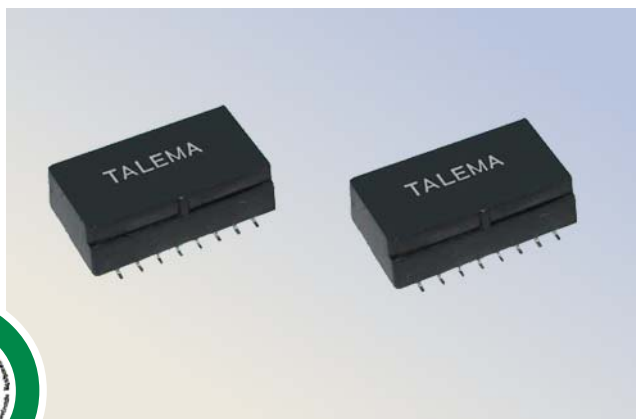

### Electrical Specifications @ 25°C

Turns Ratio: **Bold** = IC side windings

### 3kV Modules comply with Reinforced Insulation Level EN60950

Part Number	L <sub>P</sub> (mH Min)	Turns Ratio ±1%	L <sub>L</sub> (µH Max)	Λ <sub>I<sub>DC</sub></sub> (mA)	C <sub>C</sub> (pF Max)	R <sub>CU<sub>P</sub></sub> (Ohms)	R <sub>CU<sub>S</sub></sub> (Ohms)	V <sub>P</sub> (Vrms)	Schematic
MHJ-200B1-XXX	30	1:1:1:1	10	4	75	1.7	1.9	3000	A
MHJ-240B1-XXX	30	1:1: <b>2:2</b>	10	4	75	1.7	3.7	3000	A
MHJ-230B1-XXX	30	1:1: <b>2.5:2.5</b>	10	4	75	1.7	4.4	3000	A

### Common Mode Quad Choke

Basic P/N + Suffix (Example: MHJ-240B1-502)	L <sub>N</sub> (µH)	R <sub>CU</sub> (Ohms)
-000	No Choke	
-470	47	0.4
-101	100	0.6
-501	500	0.4
-502	5000	1.1
-123	12000	1.8

S<sub>0</sub> Transformer modules comply with Reinforced Insulation Level EN60950:1992/A4: 1997, para. 2.9.4.4 when tested in accordance with 6.4.1

### Test Conditions:

1. Polarity and Turns Ratio: **w1** : **w2** : w3 : w4 ±1%
2. Inductance: 30mH Minimum, line side windings (w3+w4) in series @ 10kHz, 100mV
3. Leakage Inductance: 10µH Max. @ 100kHz, 100mV
4. Quad Choke Inductance: 100kHz, 20mV
5. Winding Capacitance: C<sub>w</sub> 150pF Max. (w3+w4)
6. Coupling Capacitance: C<sub>c</sub> 75pF Max. (w3+w4 to w1+w2) @ 10kHz, 100mV
7. High Voltage Test: 3kV, 1 minute U(w3+w4 to w1+w2)  
 High Voltage Pulse Test: U<sub>PULSE</sub> (w3+w4 to w1+w2); 10kV<sub>OP</sub> for 1,2µs/50µs wave form  
 U<sub>PULSE</sub> (w3+w4 to w1+w2); 10kV<sub>OP</sub> for 10µs/700µs wave form

### MHJ Module

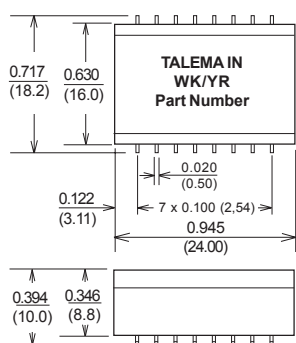

Pins - 0.012 x 0.020 (0.3 x 0.5)

Surface Coplanarity will be 0.004(0.10) maximum

### Suggested Pad Layout

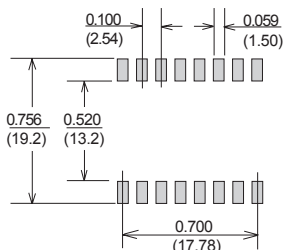

Dimensions: Inches (Millimeters)

Tolerance: ±0.010 (0.25) unless specified otherwise

### Schematic

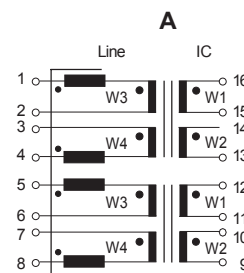

# ISDN S<sub>0</sub> THT Interface Modules

## Features

- excellent output characteristics ensures compliance with CCITT.I.430 pulse waveform template when used with recommended IC pairing
- excellent and consistent balance between windings
- modular design maximizes suppression effectivity and transmission properties
- full compatibility with all common IC's
- HVM Series approved to IEC950 (see note at bottom of chart)
- manufactured in ISO-9001:2000, TS-16949:2002 and ISO-14001:2001 certified Talema facility
- fully RoHS compliant and meets lead free reflow level J-STD-020C
- operating temperature: -40° to 85°C
- storage temperature: -40 to +125°C

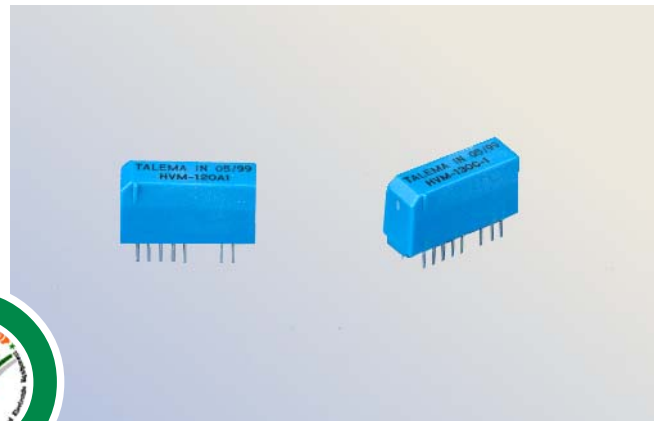

## Electrical Specifications @ 25°C

Turns Ratio: **Bold** = IC side windings

### ISM Series DIL Modules comply with Supplementary Insulation Level EN60950, UL1950 and UL1459

Part Number	L <sub>P</sub> (mH Min)	Turns Ratio	L <sub>L</sub> (μH Max)	I <sub>DC</sub> <sup>Λ</sup> (mA)	C <sub>C</sub> (pF Max)	R <sub>CU</sub> P (Ohms)	R <sub>CU</sub> S (Ohms)	V <sub>P</sub> (Vrms)	Schematic
ISM-100C1-XXX	30	1/1:1/1	10	5	150	1.7	2.0	1500	C1
ISM-120A1-XXX	30	1/1:4	10	5	150	1.7	4.0	1500	A1
ISM-130C1-XXX	30	1/1: <b>2.5/2.5</b>	10	5	150	1.7	4.6	1500	C1
ISM-140C1-XXX	30	1/1: <b>2/2</b>	10	5	150	1.7	4.0	1500	C1

### HVM Series DIL Modules are Approved to IEC950 - Supplementary Insulation Level

HVM-100C1-502	30	1/1:1/1	10	5	75	1.7	2.1	1500	C1
HVM-120A1-502	30	1/1:4	10	5	75	1.7	4.2	1500	A1
HVM-130C1-502	30	1/1: <b>2.5/2.5</b>	10	5	75	1.7	4.9	1500	C1
HVM-140C1-502	30	1/1: <b>2/2</b>	10	5	75	1.7	4.2	1500	C1

### Common Mode Quad Choke

Basic P/N + Suffix (Example: ISM-100C1-470)	L <sub>N</sub> (μH)	R <sub>CU</sub> (Ohms)
-000	No Choke	
-470	47	0.30
-101	100	0.40
-501	500	1.20
-502	5000	1.00

### Note:

The HVM Series with a 5mH quad choke is approved to IEC950 Supplementary Insulation level for connection between SELV and TNV in systems which have a rated mains supply of 250Vrms to earth (Certificate Nr. NL2731). Other choke inductances also available.

**Standard Packaging:** Anti-static tubes

## ISM & HVM THT Modules

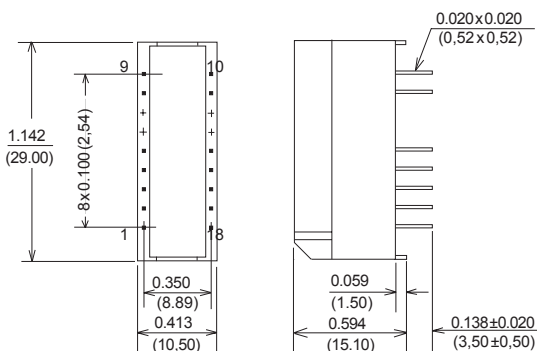

Dimensions: Inches (Millimeters)  
Tolerance: ±0.010 (0.25) unless specified otherwise

## Schematic

